

How to Attach your New D-Shelves to your Existing Stands

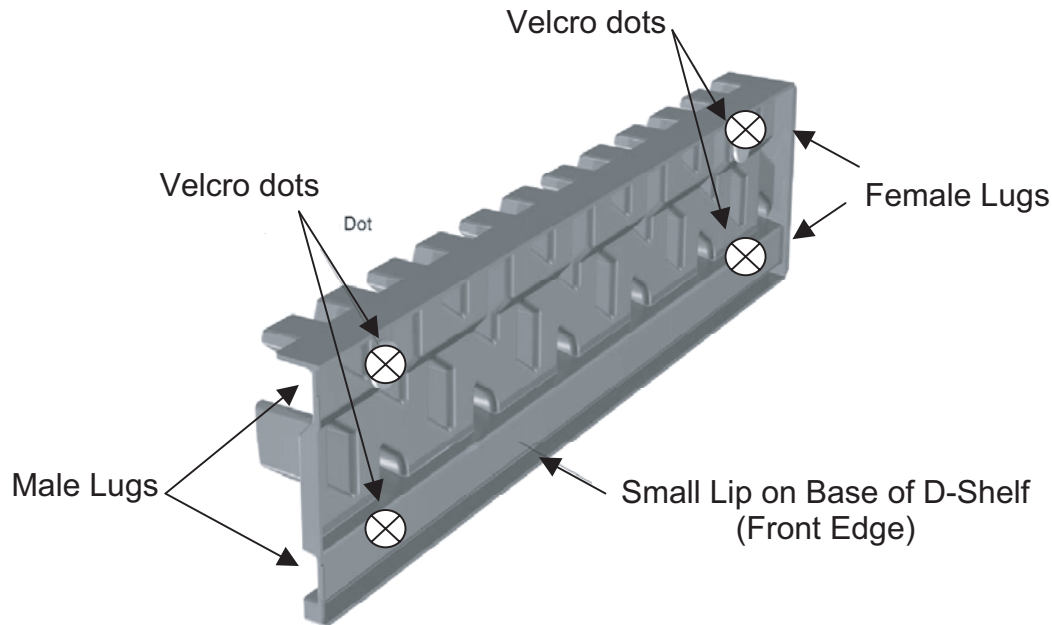

Instructions

1. Start laying shelves from Right to Left (when facing existing shelf).
2. When laying shelves, make sure the small lip on the base of the front of the shelf is hanging over (and flush to) the edge of the existing shelf.
3. TGI have supplied four pairs of Velcro dots per D-Shelf section
4. Place a furry dot on each of the four corners of the base of each shelf, as in the diagram above.
5. Then join a spiky dot to each furry dot, so the sticky side is facing away from the shelf.
6. With the Velcro dots attached to the D-Shelf, position this section and fix to your existing shelf, keeping the lip on the base just over the front edge of your shelf.
7. Repeat for each D-Shelf section, making sure to firmly click together the male lugs into the female lugs on the ends of the shelves to lock each section to the next.

On request, TGI are able to cut D-Shelves to any size in order to fill any gaps on your existing shelves left by the installation of your new D-Shelves.